

JPX-10

HAND OPERATED SCISSOR PALLET TRUCK

- ❖ Simple Structure, good looking appearance
- ❖ One cylinder system guarantees
 - No risk of oil leakage
 - No risk of dropping to the second piston suddenly
- ❖ Newest design of handle



TECHNICAL SPECIFICATION

ITEM		JPX-10
Capacity	Kg	1000
Min. fork height	mm	85
Max. fork height	mm	800
Size of fork	mm	162x50
Length of Fork	mm	1150
Width overall fork (adjust/fixed)	mm	540/680
N.W.	Kg	128/133
Fork rollers	mm	φ75x80
Big wheel	mm	φ180x50

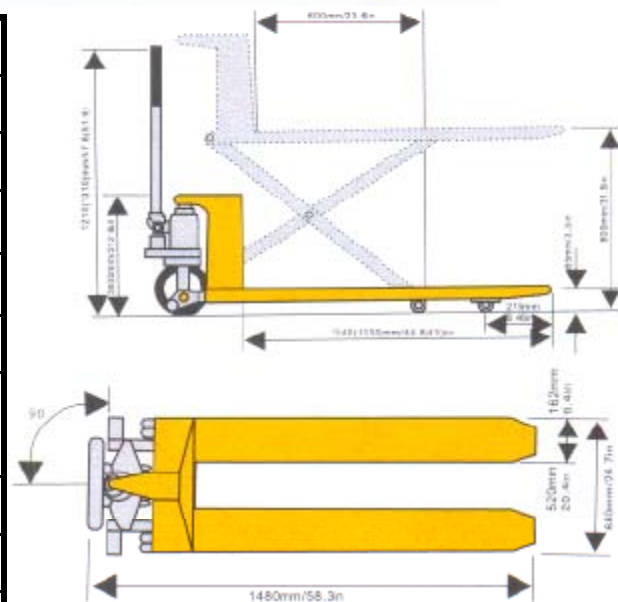

* Materials and specification are subject to change.



Jost's Engineering Company Limited

Plot No.C-7 Road No. 12,Wagle Industrial Estate, Thane 400604 (Maharashtra) India
 Phone 022-25821727 Fax 022-25823478
 E-Mail salesthane@josts.in Internet www.josts.com
 (Registered Office: Great Social Building, Sir Phirozeshah Mehta Road, Mumbai 400 001)
 Branches:
 Bangalore 080-22263707, Baroda 0265-2351642, Chennai 044-26268536, Kolkata 033-22482257,
 New Delhi 011-39839446, Pune 020-25434565, Secunderabad 040-27900300.