

# TUSKER

(Tow Trucks)

Capacity 8000 / 10000 Kg.



Note: Picture shown here may include optional attachments / offerings on Extra Cost

- MOSFET stepless speed controller and heavy duty contactors.
- Towing capacity up to 10000 kg.
- Pollution free and user friendly.
- Easy and comfortable to ride.
- Effortless steering operation.

The Jost's electric tow truck is a four wheel battery operated material handling equipment used for towing load up to 8,000 / 10,000 kg over long distances on asphalt or smooth concrete road. It is ideal for use in inter-plant transportation, factories, airports, railways and large processing plants. Jost's leads the way with tough, dependable industrial towing trucks.

**Operators Area :** Ergonomically convenient operator's area provides operators comfort. All controls are located at easily accessible reach with ample leg room. Adjustable seat (Optional) further enhances operator's comfort.

**Drive :** The vehicle is driven by an AC motor of suitable rating with class 'F' insulation powered by suitable battery capacity. Efficient power transmission to rear wheels is through noise free dual stage gear reduction unit and differential mechanism.

**Drive Control :** Microprocessor based MOSFET controller enables smooth step less acceleration, variable speed control and precise inching movement. The controller comes with self diagnostic feature which monitors the control system for fault diagnostic purposes. The controller also enables regenerative braking thereby increasing the battery utilisation period.

**Brakes :** Automatic braking is enabled by regenerative braking when the operator removes his foot from the acceleration pedal. Service braking is ensured by self adjusting brakes with heavy duty brake linings and is effected by hydraulic braking actuated by ergonomically located foot pedal. Parking brake is through expandable shoes operated by cable connected to a hand operated lever located on operators left hand side.

**Power Steering :** Hydrostatic power steering system with automotive type tilt able steering column enables virtually fatigue free operation while maneuvering in confined area. The hydraulic steering unit, controls the steering action hydraulically through the steering cylinder mounted on the steer axle. The steering column is operated by 16" hand wheel provided with foam grip for operator's comfort.

**Steer Axle :** Articulating hydraulic steer axle of robust construction ensures accurate steering geometry, minimum tyre wear and sharp angle steering for greater maneuverability. It comprises of hardened steel bushing for the center pivot for prolonged trouble free life and integrated balanced, hydraulic cylinder located at convenient accessible position for easy maintenance.

**Wheels :** The truck is supplied with Solid cushion tyres as standard for operating over a variety of surface conditions. The Solid cushion tyres with split rim construction provides adequate resilience during operation. Solid rubber tyres or Non-marking tyres can also be supplied as an option on request.

**Chassis and Canopy :** Chassis is fabricated from heavy steel plates for excellent rigidity and strength. Battery compartment with cover is integrated with chassis and supports the operator's seat without compromising the accessibility of battery for routine maintenance. A hand lever operated self return towing arrangement is provided at the rear of the truck which can be operated by the operator without dismounting from the seat. The chassis is adequately balanced for towing the specified loads without any problem. The canopy is made of hollow section for rigidity and protects the operator against the hazards of falling objects.

**Instrumentation and control :** The hour meter and battery discharge indicators are provided as a standard on the front panel. The On-Off switch, forward reverse direction switch are located within easy reach.

**Accessories :** The truck comes with head / tail / brake / side indicator lights, reverse light / horn, and rear view mirror as standard. Revolving lights can also be supplied as an option.

**Battery :** The vehicle is supplied with suitable traction battery with lead acid cells and adequate capacity rating as standard for non intensive application. Optional higher capacity rating batteries can also be provided for more intensive applications.

**Charger :** Microprocessor based charger of suitable ratings can be supplied, depending on the battery selection.

## (Tow Trucks) Capacity 8000 / 10000 Kg.

### Performance Data

Identification	Mode	nos.	JETW – 80	JETW – 100
	Controller	type		AC
Operation	type		Seated	Seated
Towing Capacity*	Kg		8000	10000
Wheelbase	Y = mm		1425	1625
Weight	Service weight incl. battery (approx.)	Kg	1650	2050
	Battery weight (approx.)	Kg	650	990
Chassis	Tyres	type	Solid Cushion	Solid Cushion
	Tyre size, front	mm	Ø460 x 127W	Ø460 x 127W
	Tyre size, rear	mm	Ø580 x 172W	Ø580 x 172W
	Wheels, front / rear (x = driven wheels)	nos.	2 x 2	2 x 2
	Track width, front	B2 = mm	960	960
Track width, rear	B3 = mm	975	975	
Basic Dimension	Overall height	h1 = mm	2200	2200
	Overall length	L = mm	2250	2450
	Battery compartment width	B4 = mm	1000	1000
	Overall width	B1 = mm	1150	1150
	Ground clearance	GC = mm	120	120
	Turning radius	Wa = mm	2450	2650
	Platform size	PL x PW = mm	500 x 1150	500 x 1150
	Platform / Towing height	h2 / h3 = mm	700 / 300	700 / 300
Front overhang	G = mm	450	450	
Performance	Travel speed # : Laden	Km / hr	7	7
	Unladen	Km / hr	10	10
	Gradient performance : Laden	%	5	5
	Unladen	%	10	10
	Service brake (foot operated)	type	Hydraulic	Hydraulic
Parking brake	type	Hand Operated	Hand Operated	
Power	Drive motor rating S2 60 min.	Kw	8	12
	Battery voltage, nominal capacity	V / Ah	48 / 375	72 / 385
	Battery charger ( 3 Phase - Automatic)	V / A	48 / 50	72 / 55
Others	drive control	type	3Φ AC	3Φ AC
	Sound level	db ( A)	85	85

Note: 1). \* = Towing capacity includes trolley weight plus pay load weight., 2). # = Max. speed can be achieved with full battery charge.

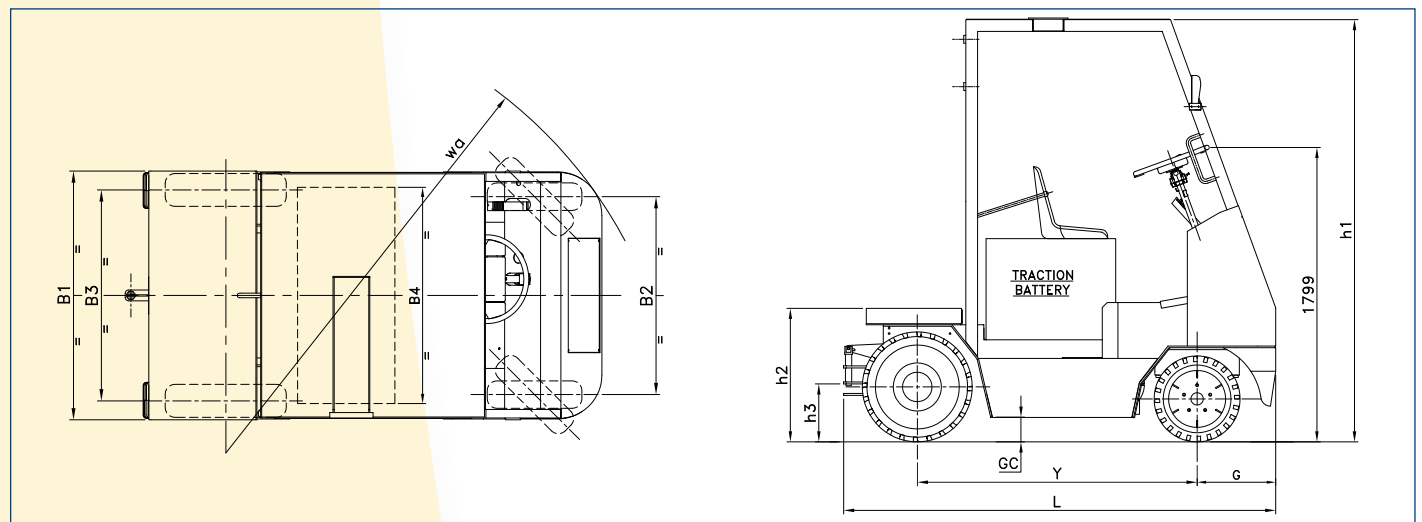

\*For any special requirements, Please contact Jost's H.O., Dimensions indicated here are subject to variations of ± 20 mm and performance ± 10%. Service weight ± 50 kg. Right to make changes and technical improvement reserved.

### Jost's Engineering Company Limited

C-7 Wagle Industrial Estate, Road No. 12, Thane - 400 604. Maharashtra. INDIA.  
T.: +91.22.6117 4000 / 2582 1727 F.: +91.22.6117 4020 E.: infomhe@josts.in

Bengaluru : +91.80.2226 3707 / 22263708 Chennai : +91.44. 2626 8536 / 2628 8407

Delhi : +91.11.4567 6000 / 14 Kolkata : +91.33.2242 9510 / 4008 1242 Pune : +91.20.2543 4350 / 90

Secunderabad : +91.40.2771 4934 / 44 / 54 Vadodara : +91.265.2351 642



SINCE 1907