

# EJE 35/40/50

(AC Drive)

Electric Pedestrian Pallet Truck  
(3500 / 4000 / 5000 kg.)



- MOSFET programmable stepless speed controller.
- Safe operation on gradients with speed control.
- Multifunction tiller head with enhanced safety.
- Unique linkage mechanism to provide jerk free lift of loaded pallet.

The new Jost's Electric Pedestrian Pallet Truck, type EJE has been designed specially for flexible handling of palletised loads for increased performance as well as long usage times. The EJE is designed particularly for heavy duty requirements of lorry loading / unloading. **Jost's Pallet trucks with AC technology provides additional advantage of reduced maintenance, improved power utilisation and improved battery life.**

**Operator Area :** The low hinged handle provide ample scope for greater maneuverability. The enclosed design feature, toe guard, safety and emergency stop buttons provide maximum safety for the operator.

**Drive :** The powerful 1.5 / 2.5 kw high performance AC motor of 1 hour rating with high over load capacity efficiently drives a low noise, two stage compact gear unit mounted directly on to the drive wheel.

**Drive Control :** Microprocessor based MOSFET controller provides smooth and stepless control of speed and acceleration. It also helps in obtaining fault diagnostic information quickly and easily. The high life cycle contactors used in the control circuit enhances dependability and productivity. The controller also has provision for dual speed setting (optional) for safe maneuvering in confined spaces.

**Chassis :** Robust construction and the stable five point contact design enhances stability during turning. The swivel side support wheels provide stability during travel and permits safe maneuvering in confined spaces. The battery holding compartment in the chassis is provided with suitable roller bed for easy removal of the battery.

**Wheels :** All wheels ( Drive wheel  $\varnothing 200 \times 85\text{mm}$  /  $\varnothing 254 \times 100\text{mm}$  wide, Load wheels  $\varnothing 85 \times 75\text{mm}$  /  $\varnothing 100 \times 140\text{mm}$  wide tandem, Support castors  $\varnothing 100 \times 40\text{mm}$  wide) are made of polyurethane material as a standard. These enable noiseless smooth ride over variety of surfaces and cause less damage to expensive flooring. These also have better ability to withstand impact loads while rolling over bumps on the surfaces. The tandem load wheel configuration ensures smooth roll over with continuous contact on the floor and enables easy negotiation over small bumps and jerks. These also enable easy entry into closed pallets.

**Tiller Head :** Multifunction tiller head with ergonomically arranged operating elements for travel, lift, lowering and horn at finger tips provide highest operator comfort and safety. It also has a belly button that provides additional safety in case of emergencies.

**Steering :** The tiller control handle configuration enable easy steering with out much effort. Steering lock at  $90^\circ$  on either side and can be operated only in limited range of handle inclinations comfortable to operator. This provides additional operational safety.

**Forks :** Robust steel fabricated forks ensure long lasting and durable service. Various options of fork lengths and with width over forks are available for different types of pallets. The fork ends are suitably tapered to provide better maneuverability while turning in confined spaces.

**Brake :** Electromagnetic disc brake with hard wearing, asbestos free liner provides instantaneous braking. When the handle is close to vertical or horizontal position, the brake becomes operational with simultaneous power cut-off.

**Hydraulic System :** Compact power pack unit with high pressure pump driven by 0.8 / 2.2 Kw sturdy compound wound motor operates the lifting mechanism comprising of low lift hydraulic cylinder and load wheel linkages and for jerk free lift of the loaded pallet for the required ground clearance. The compact system consumes less battery power and is designed with very little scope for hydraulic losses.

**Safety :** The truck is equipped with automatic lift cut off at 80% battery discharge condition for enhanced safety, emergency power cut-off switch on chassis panel and anti-collision switch on tiller head. The hydraulic circuit has safety feature like pressure relief valves and non return valves. The toe guard at the rear, guards the operator against inadvertent accidents. EJE 50 is equipped with pressure compensated flow control valve for cushioning effect while lowering of loaded forks.

**Servicing :** The modular service friendly design with easily removable front cover provides easy access to all components for servicing thus saving valuable time during maintenance.

**Battery :** 24V / 330Ah traction batteries for 3500 / 4000 / 5000 kg models are provided as standard supplies.

**Charger :** 24V / 35Amp high frequency constant current automatic charger is supplied as a standard.

## Specification

	Model	Nos.	EJE 35	EJE 40	EJE 50
<b>Performance Data</b>	Drive	type	AC	AC	AC
	Capacity	Q = Kg.	3500	4000	5000
	Load Center for rated capacity	C = mm	600	600	600
	Load distance (from load wheel to fork face)	L2 = mm	870	870	760
	Travel speed (min.), laden	kmph	4.0	4.0	4.5
	Travel speed, unladen	kmph	4.5	4.5	6.5
	Lift speed, laden / unladen	cm/s	1.6 / 2.5	1.4 / 2.5	2.2 / 2.5
	Lowering speed, laden / unladen	cm/s	3.1 / 2.5	3.3 / 2.5	3.3 / 2.3
	Gradient performance, laden / unladen	%	6 / 16	5 / 16	3 / 16
	Battery weight, apx.	Kg.	310	360	385
	Service weight incl. 'battery, apx.	Kg.	790	810	850
<b>Technical Data</b>	Wheelbase	Y = mm	1570	1570	1460
	Wheels	type	Polyurethane	Polyurethane	Polyurethane
	Load Wheel	mm	Ø85x75W	Ø85x75W	Ø100x140W
	Side support castor wheel	mm	Ø100x40W	Ø100x40W	Ø100x40W
	Drive wheel	mm	Ø200x85W	Ø200x85W	Ø254x100W
	Wheels, number front / rear (x = driven wheels)	nos.	1x + 2 / 4	1x + 2 / 4	1x + 2 / 4
	Track width, front / rear	B2 / S = mm	606 / 385	606 / 385	666 / 440
	Overall length	L = mm	2020	2020	1920
	Lift	h1 = mm	115	115	125
	Fork lowered height	h = mm	90	90	110
	Safety clearance	a = mm	100	100	100
	Front overhang	G = mm	264	264	270
	Overall width	B1 = mm	850	850	850
	Fork dimensions	s/e/l = mm	65/185/1150	65/185/1150	80/240/1150
	Load Wheel / Forks tip distance	X = mm	186	186	190
	Width over forks (WOF)	m = mm	570	570	680
	Ground clearance (Center of wheel base)	GC = mm	35	35	30
	Turning radius	Wa = mm	1900	1900	1800
	Drive control	type	Mosfet	Mosfet	Mosfet
	Drive motor rating S2 = 60 min.	kW	1.5	1.5	2.5
Lift motor rating S2 = 1.8 min., S3 = 7%	kW	0.8	0.8	2.2	
Sound level at driver's ear	db(A)	85	85	85	

### Working Aisle Width Ast. incl 200mm safety clearance

Pallet size c x b	Position		3500 kg	4000 kg	5000 kg
800 x 1200	Crosswise	mm	2400	2400	2350
800 x 1200	Lengthways	mm	2550	2550	2450
1000 x 1200	Crosswise	mm	2400	2400	2550
1000 x 1200	Lengthways	mm	2640	2640	2350
1200 x 1200	Lengthways	mm	2740	2740	2650

Note: 90° stacking aisle width.

### Optional Fork Lengths and Widths

Capacity (kg)	Fork length (mm)	Width over fork (mm)	
3500	1150	680	750
4000	1150	680	750
3500	1250	680	750
3000	1400	680	750
3000	900	680	750

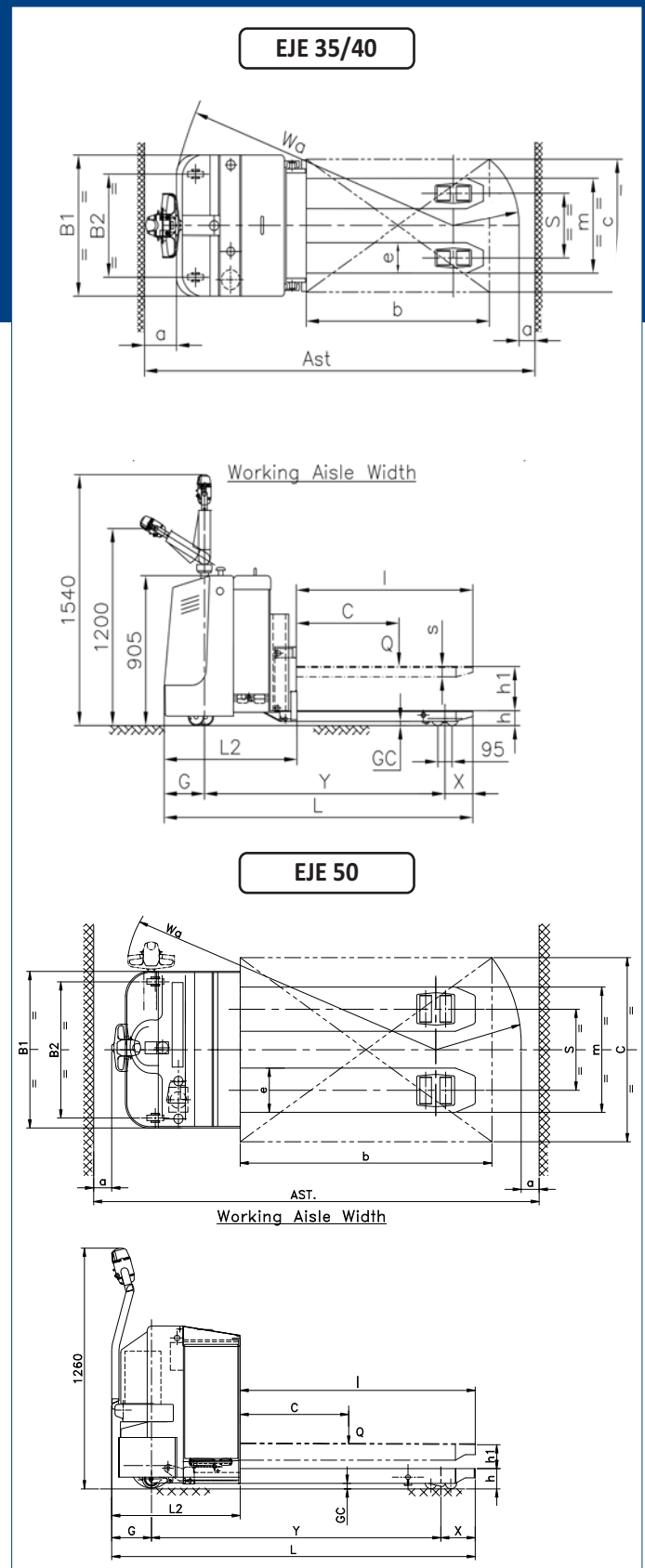

\*For any special requirements, Please contact Jost's H.O., Dimensions indicated here are subject to variations of ± 20 mm and performance ± 10%. Service weight ± 50 kg. Right to make changes and technical improvement reserved.

## Jost's Engineering Company Limited

C-7 Wagle Industrial Estate, Road No. 12, Thane - 400 604. Maharashtra. INDIA.

T.: +91.22.6117 4000 / 2582 1748 F.: +91.22.6117 4020 E.: infomhe@josts.in

Bengaluru : +91-80-4123 4775 / 4885 Chennai : +91.44. 2626 8536 / 2628 8407

Delhi : +91.11.4567 6000 / +91.11.4567 6014 Kolkata : +91.33.2242 9510 / 4008 1242

Pune : +91.20.2543 4350 / 90 Secunderabad : +91.40.2771 4934 / 44 / 54 Vadodara : +91.265.2351 642



Since 1907